

High Efficiency Power Amplifier Module (OEM Version)

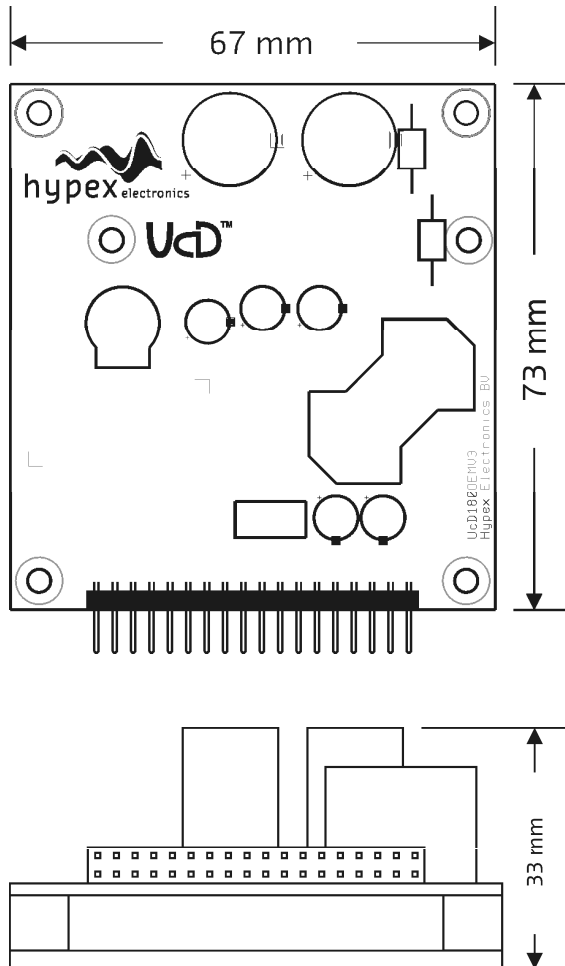

Highlights

- Flat, fully load-independent frequency response
- Low output impedance
- Very low, frequency-independent THD
- Very low noise
- Fully passive loop control
- Consistent top performer in listening trials

Features

- Runs on unregulated +/- rails
- Pop-free start and stop control
- Differential audio input
- On-board clipping detection
- DC-fault detection
- Overcurrent and overvoltage protection
- Weight: 100g / Height: 33mm

Applications

- Monitor loudspeakers for recording and mastering studios
- Audiophile power amplifiers for professional and consumer use
- Public Address systems
- Home theatre systems
- Active loudspeakers

Description

The UcD180™ (OEM version) amplifier module is a self-contained high-performance class D amplifier intended for a wide range of audio applications, ranging from Public Address systems to ultrahigh-fidelity replay systems for studio and home use. Chief distinguishing features are flat frequency response irrespective of load impedance, nearly frequency-independent distortion behaviour and very low radiated and conducted EMI. Control is based on a phase-shift controlled self-oscillating loop taking feedback only at the speaker output.

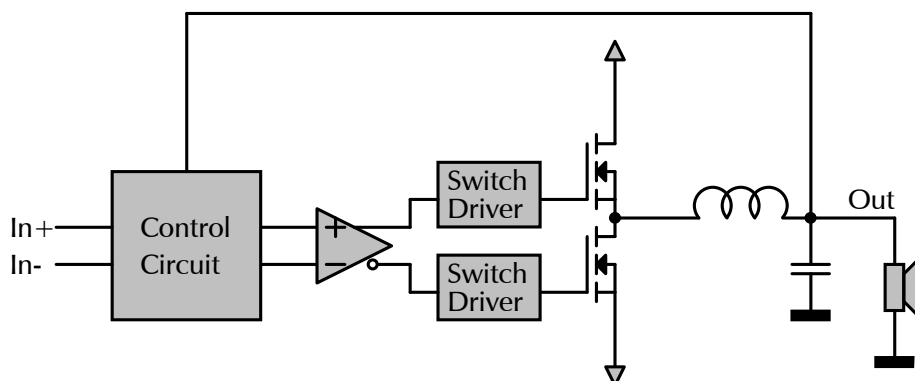

Performance data

Power supply = +/-45V, Load=4Ω, MBW=40kHz, unless otherwise noted

Item	Symbol	Min	Typ	Max	Unit	Notes
Output Power	P_R	180	-	-	W	THD=1%
Distortion	THD+N	-	0.1	0.15	%	20Hz<f<20kHz. Pout<P _R /2
		-	-	0.05	%	20Hz<f<20kHz Pout=1W
Output noise	U_N	-	-	80μ	V	Unwtd, 20Hz-20kHz
Output noise (UcD only)	U_N	-	-	30μ	V	Unwtd, 20Hz-20kHz
Output Impedance	Z_{OUT}	-	-	20m	Ω	f<1kHz
		-	-	150m	Ω	f<20kHz
Power Bandwidth	PBW		20-35k		Hz	
Frequency Response		10	-	50k	Hz	+0/-3dB. All loads.
Voltage Gain total	A_V	25.5	26	26.5	dB	
Supply Ripple Rejection	PSRR		65		dB	Either rail, all frequencies.
Efficiency	η		92		%	Full power
Idle Losses	P_0		4		W	
Standby Current	I_{STBY}		10m		A	
Current Limit			10		A	Stop mode after limiting 40ms

Audio Input Characteristics

Item	Symbol	Min	Typ	Max	Unit	Notes
Input Impedance (buffered input)	Z_{IN}		100k		Ω	Either input to ground
Input Impedance (unbuffered input)	Z_{IN}		1k8		Ω	Either input to ground
Common Mode Rejection Ratio	CMRR		75		dB	All frequencies

Absolute maximum ratings

Correct operation at these limits is not guaranteed. Operation beyond these limits may result in irreversible damage.

Item	Symbol	Rating	Unit	Notes
Power supply voltage	V_B	+/-50	V	Unit shuts down when either rail exceeds 52V
Peak output current	$I_{OUT,P}$	10	A	Unit current-limits at 10A
Input voltage	V_{IN}	+/-12	V	Either input referred to ground
Air Temperature	T_{AMB}	65	°C	
Heat-sink temperature	T_{SINK}	90	°C	User to select heat sink to insure this condition under most adverse use case

Recommended Operating Conditions

Item	Symbol	Min	Typ	Max	Unit	Notes
Power supply voltage	V_B	30	45	50	V	
Load impedance	Z_{LOAD}	1			Ω	
Source impedance	Z_{SRC}			7k	Ω	Differential. Corresponds to 3dB noise increase.
Effective power supply storage capacitance	C_{SUP}	4700μ			F	Per rail, per attached amplifier. 4Ω load presumed.

Connections

In order to ease connecting the amplifier, all necessary connections to operate the amplifier are grouped in one standard 2.54mm pitch dual row 36 pin header.

Pin	Function
1, 2, 3, 4	Positive power supply connection
5, 6, 7, 8	Power supply ground connection*
9, 10, 11, 12	Negative power supply connection
13, 14, 15, 16, 18	Loudspeaker connection (cold)*
17	Negative loudspeaker feedback
19	Positive loudspeaker feedback
20, 21, 22, 23, 24	Loudspeaker connection (hot)
25	Buffered inverting audio input
26	Buffered inverting audio output
27	Unbuffered inverting audio input
28	Ground*
29	Buffered non-inverting audio input
30	Buffered non-inverting audio output
31	Unbuffered non-inverting audio input
32	Clipping detection output (open collector)
33	DC-error output (open collector)
34	ON/OFF control (active low)
35	Amplifier Ready (I ² C SDA, not yet implemented)
36	NC, (I ² C SCL, not yet implemented)

* Physically connected to the same potential (ground).

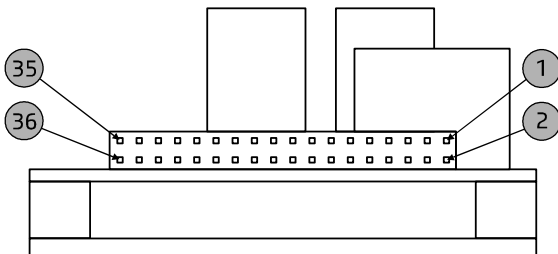

Fig1. Connector pinning UcD180TM (OEM version).

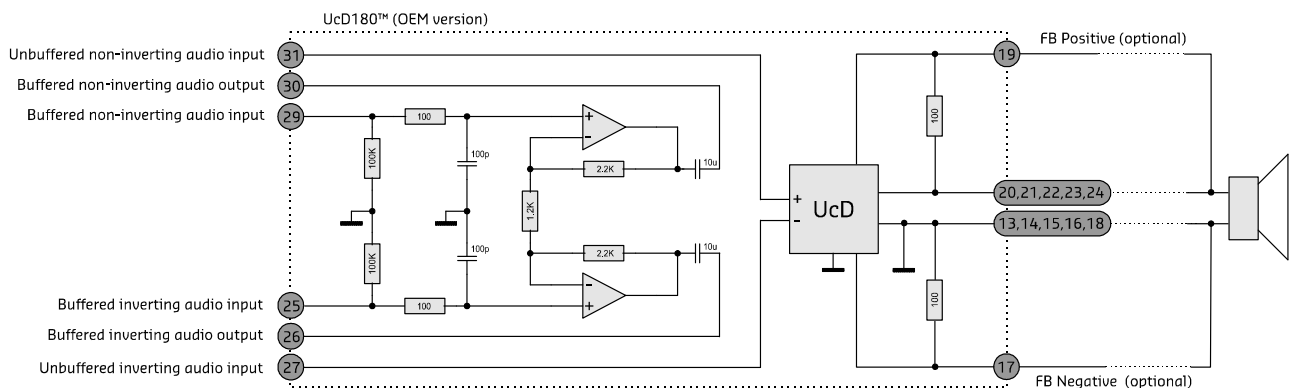

Fig2. UcD180TM (OEM version) block diagram clearly showing the signal path routing and optional loudspeaker feedback connections.

Clipping Detection Characteristics

The UcD180™ (OEM version) has an integrated output clipping detection which will pull pin 32 low in case of such an event.

Item	Min	Typ	Max	Unit	Notes
Voltage on pin 32, clipping			1	V	Internal open collector*

* Must be pulled to a positive voltage by means of an external resistor.

DC-fault Detection Characteristics

The UcD180™ (OEM version) has an integrated DC-error detection which will pull pin 33 low in case of such an event. It is recommended to sense this fault condition and to interrupt both power supply lines in such an event.

Item	Min	Typ	Max	Unit	Notes
Voltage on pin 33, DC-error			1	V	Internal open collector*

* Must be pulled to a positive voltage by means of an external resistor.

Amplifier ON/OFF Characteristics

The UcD180™ (OEM version) is enabled by pulling pin 34 low. Leaving pin 34 floating will put the amplifier in standby.

Item	Min	Typ	Max	Unit	Notes
Voltage on pin 34, left floating			6,5	V	Internally pulled up*

* Must be pulled low by means of an open collector.

Amplifier Ready Characteristics

The UcD180™ (OEM version) has an integrated Amplifier Ready condition which will pull pin 35 high to indicate that the amplifier shut itself down due to an error. This error can be either an overvoltage event or a shorted output.

Item	Min	Typ	Max	Unit	Notes
Voltage on pin 35, error			5,6	V	Internally pulled up

Signal path characteristics

The UcD180™ (OEM version) enables the user to choose between two different ways of input signal routing.

- In order to use the on-board buffer opamp (TL072) two external connections need to be made: pins 30, 31 and pins 26, 27 must be tied together. The amplifier is driven through both inputs 25 and 29.
- If the user desires to utilize his own input buffer circuitry no external connections need to be made. The amplifier is now driven through inputs 27 and 31. Customer needs to take into account that the input impedance of the UcD core is relatively low (1k8).

Optional remote (kelvin) feedback

When maximum control of the loudspeaker is needed it is possible to include the loudspeaker cables in the UcD control loop thus eliminating all negative effects of long cables etcetera.

Connect both the positive feedback (pin 19) and negative feedback (pin 17) connections as close to the loudspeaker as possible. No extra connections are needed.

Amplifier start-up delay

During initial power up the amplifier is disabled for approx. 1.5s regardless of the state of pin 34. Once powered up there is no start or stop delay. Pin 35 (Amplifier Ready) remains high during the initial power up.

Typical Performance Graphs

THD vs. Power (1kHz, 4Ω)

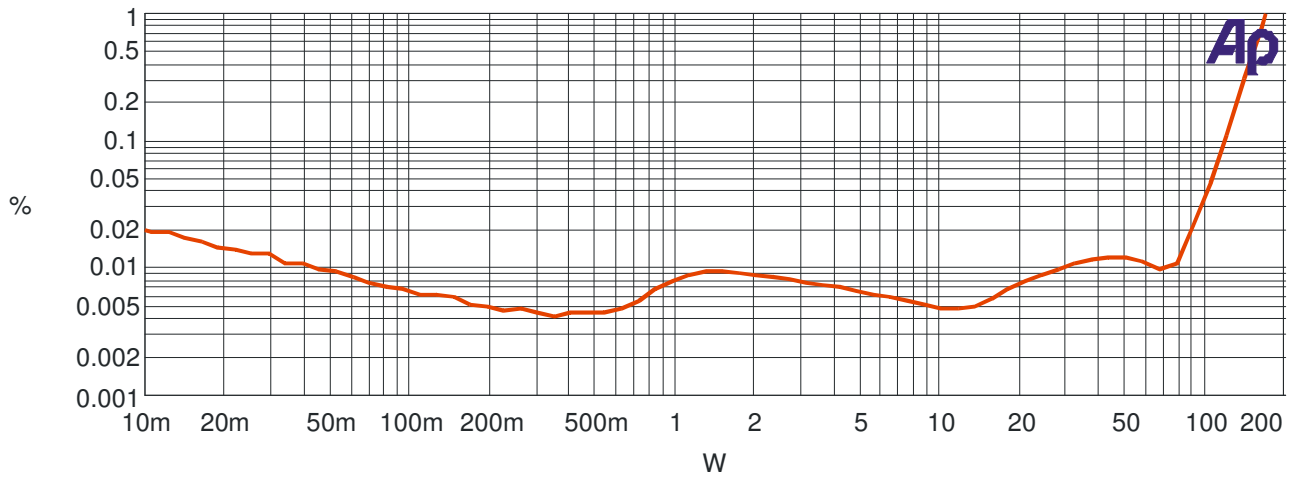

THD vs. Frequency (8Ω)

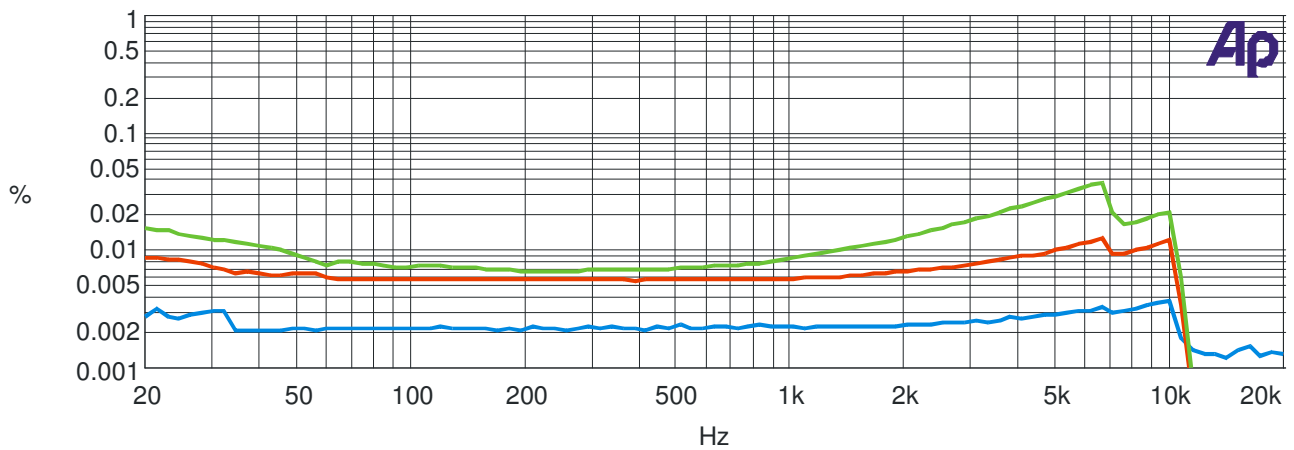

From top to bottom: 40W, 10W, 1W

Frequency Response (4Ω, 8Ω and open circuit)

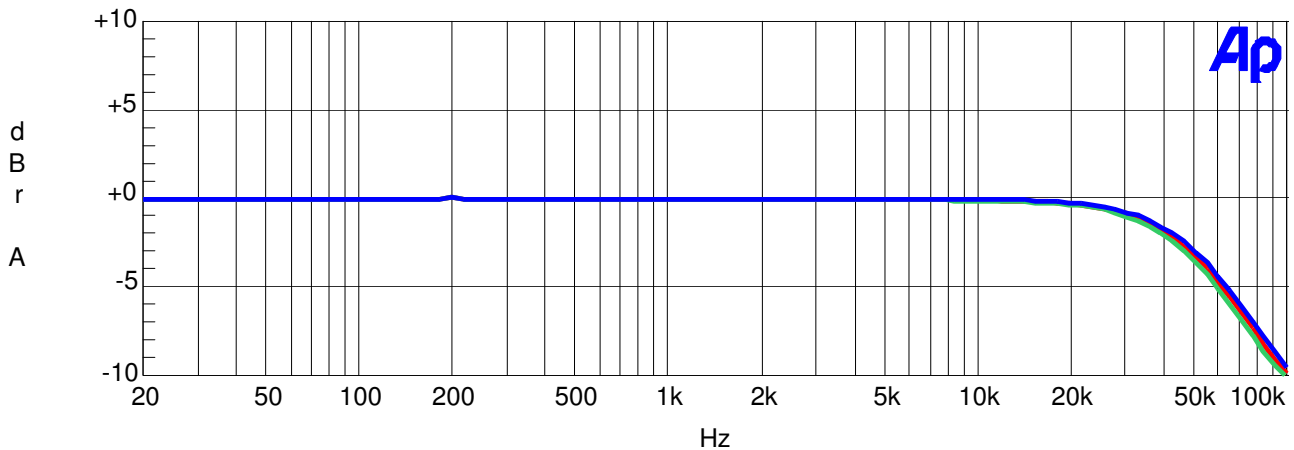

From top to bottom: open circuit, 8Ω, 4Ω

Output Impedance

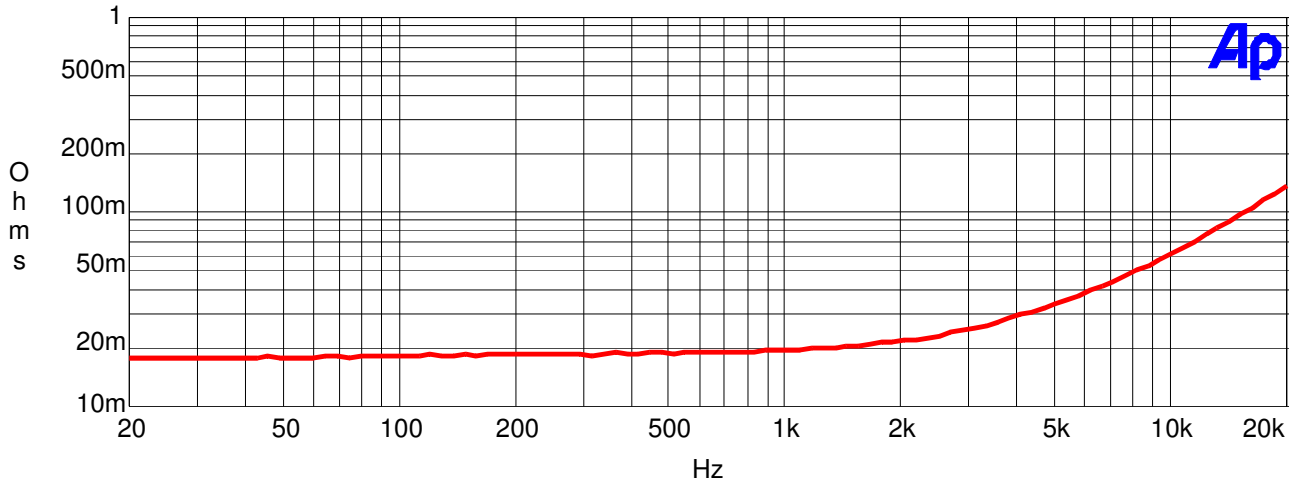

19+20kHz IMD (10W, 8Ω)

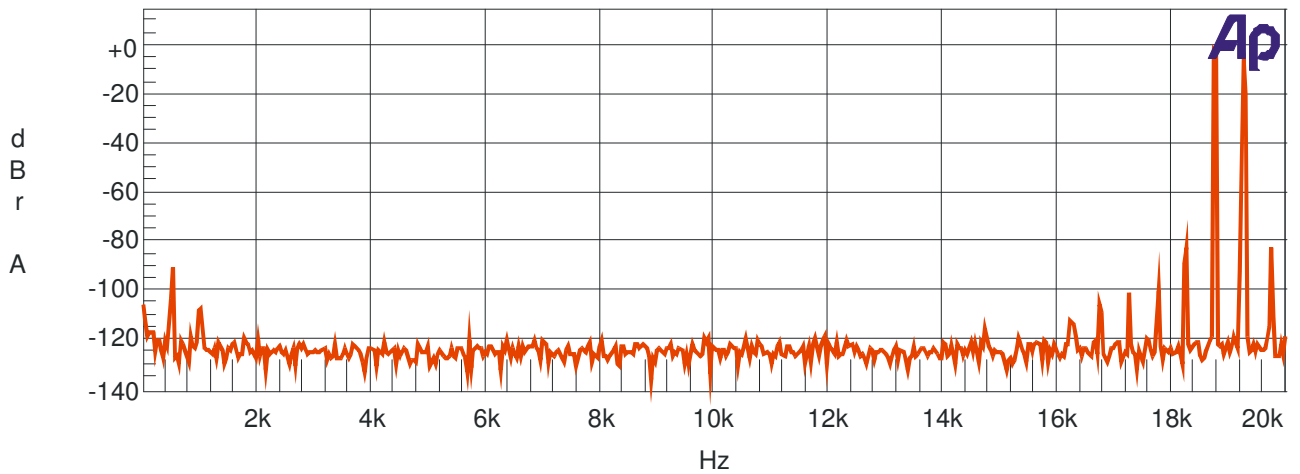

Connector layout. Top view / Frontview

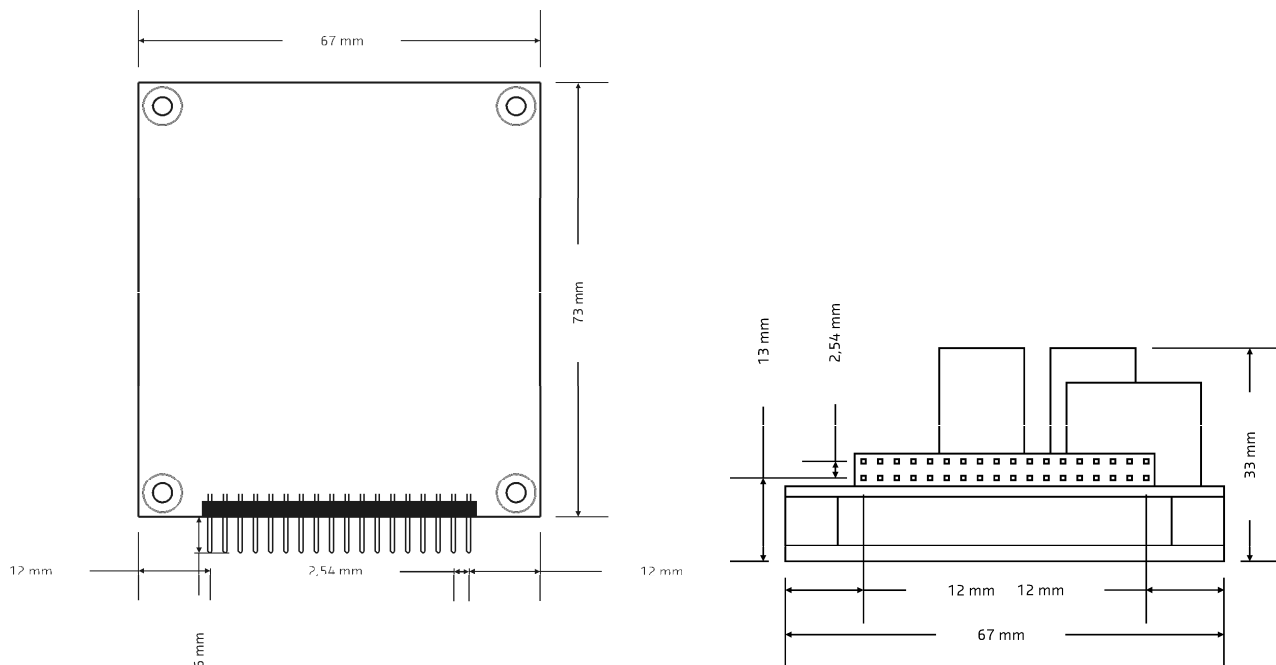

Heatsink drill pattern. Bottom view.

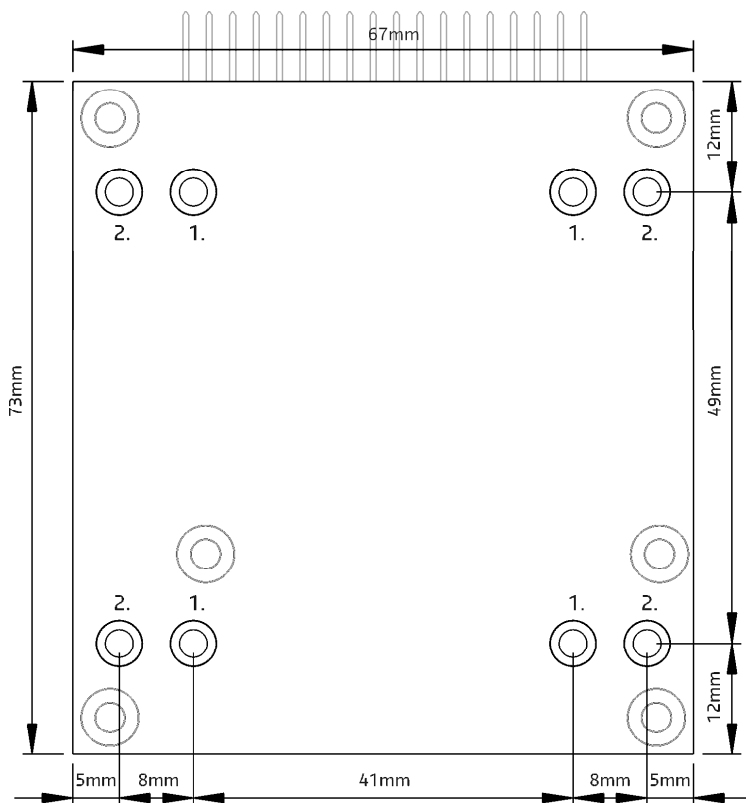

1. Push-in nut UNC 6-32
2. Push-in nut Metric M3